

Operating Instructions

Hot Melt Applicator

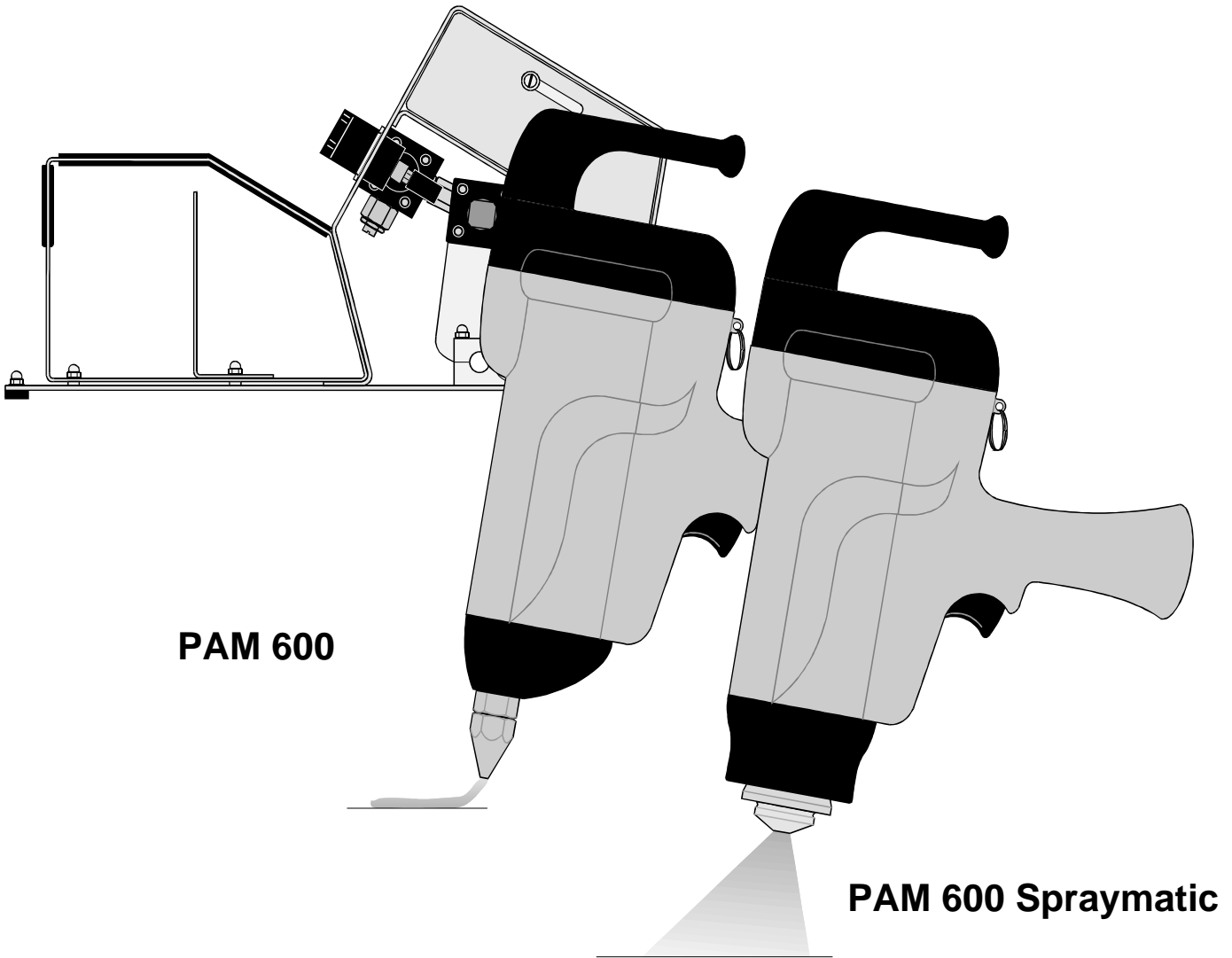

PAM 600

PAM 600 Spraymatic



Read these instructions carefully before putting into service! Keep them for future reference!
Adhering to the operating and safety instructions and all statutory regulations is the responsibility of the operator.

PAM®

FASTENING TECHNOLOGY, INC.
Division of BUEHNEN Group, Germany

Fastening Technology Inc.

2120 Gateway Blvd., Charlotte N. C. 28208





P.O. Box 669063, Charlotte N.C. 28266

Tel. (704) 394 3141, Tfx. (704) 394 9339

Contents

| | | |
|---|--|----|
| 1 | Specification | 4 |
| 2 | Safety | 5 |
| | 2.1 Normal use | 5 |
| | 2.1.1 Scope of application | |
| | 2.1.2 Restriction of use | |
| | 2.2 Potential hazards | 5 |
| | 2.3 Instruction on safe operation | 5 |
| 3 | Operating settings | 6 |
| | 3.1 Setting up | 6 |
| | 3.2 Connecting up | 6 |
| | 3.3 Switching on | 6 |
| | 3.4 Changing the temperature setting | 6 |
| 4 | Operation | 6 |
| | 4.1 Filling | 6 |
| | 4.2 Applying and metering hot melt glue | 7 |
| | 4.3 Setting the spray (PAM 600 Spraymatic) | 7 |
| | 4.4 Automatic temperature reduction system ACE (Anti Char Electronic) | 7 |
| | 4.5 Stopping work / End of shift | 7 |
| | 4.6 Troubleshooting and remedying faults | 7 |
| 5 | Maintenance / Servicing | 8 |
| | 5.1 Maintenance intervals | 8 |
| | 5.2 Cleaning | 8 |
| | 5.2.1 Cleaning the nozzle | |
| | 5.3 Nozzle systems | 9 |
| | 5.3.1 Changing the conical nozzle (PAM 600) | |
| | 5.3.2 Changing the nozzle foot (PAM 600) | |
| | 5.3.3 Changing the nozzle-setting (PAM 600) | |
| | 5.3.4 Changing the spiral nozzle, compression spring and ball (PAM 600 Spraymatic) | |
| | 5.4 Increasing the cover pressure | 10 |
| | 5.5 (Setting the spray after-air (PAM 600 Spraymatic) | 10 |
| 6 | Repairs | 10 |
| 7 | | |

Explanation

| | |
|---|--|
|  | Danger! Follow these instructions to avoid injuries and/or damage to property! |
|  | Directions! Follow these instructions to avoid malfunctions and/or wrong operation! |
|  | Actions to be carried out by user. |
|  | Result of the action. |
| (#) | The position numbers refer to the figures at page 3. |

Arrangement

Supply unit

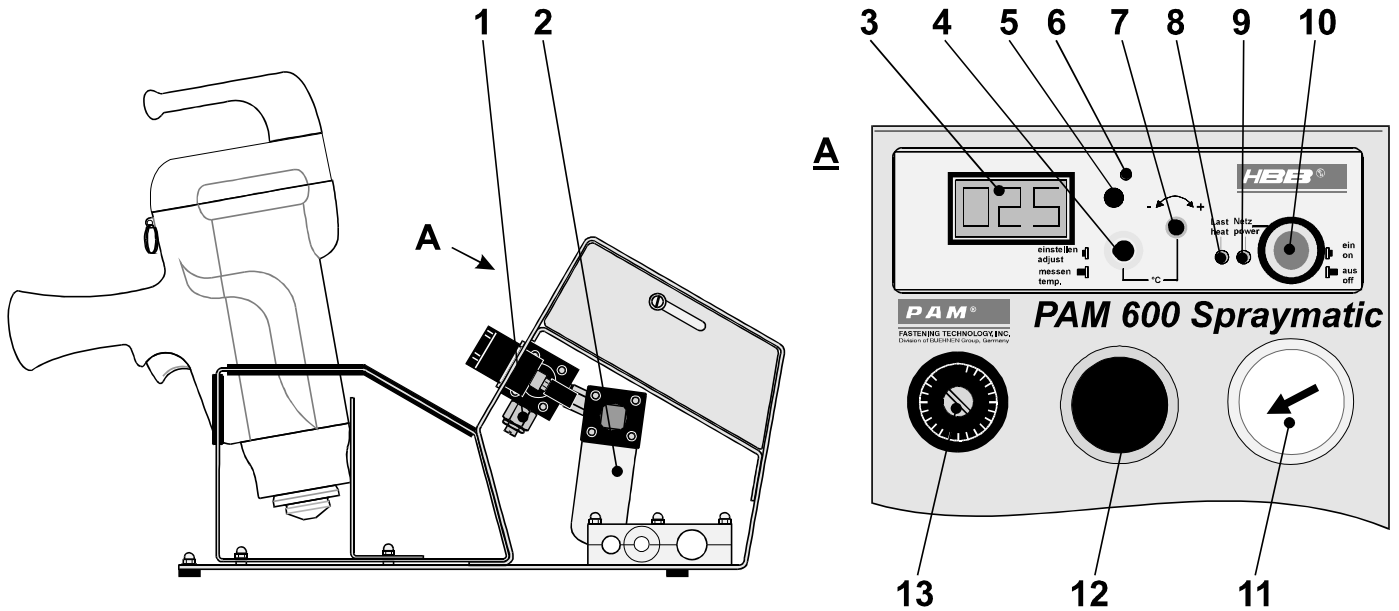

Applicator

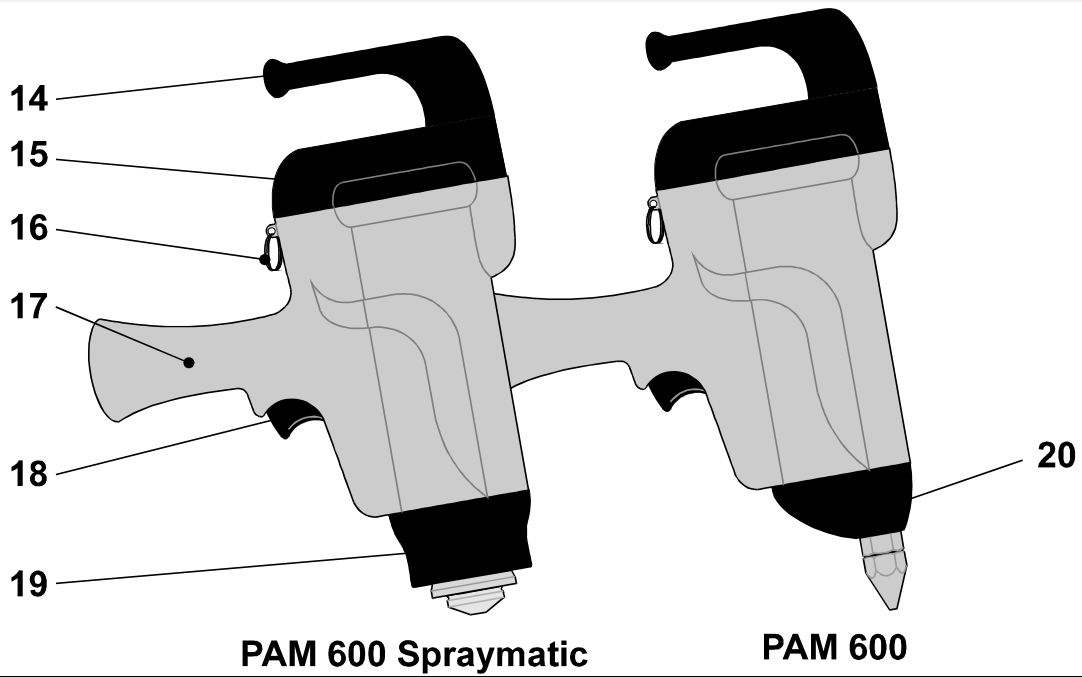

PAM 600 Spraymatic

PAM 600

| POS | Description |
|-----|--|
| 1 | Safety valve |
| 2 | Water separator |
| 3 | Digital display |
| 4 | Push switch „ADJUST/MEASURE“ |
| 5 | Blind plug |
| 6 | „ACE“ light, red |
| 7 | Rotary knob for temperature adjustment |
| 8 | „HEAT“ light, red |
| 9 | Power switch |
| 10 | Pressure indicator |
| 11 | Pressure gauge |

| POS | Description |
|-----|--------------------------|
| 12 | Pressure reduction valve |
| 13* | Spray air choke |
| 14 | Lid with handle |
| 15 | Cover |
| 16 | Suspension loop |
| 17 | Handle |
| 18 | Trigger valve |
| 19 | Protection cap |
| 20 | Diffusor cap |

*) only PAM 600 Spraymatic

Specification

1 Specification

| Description | PAM 600 | PAM 600 Spraymatic |
|---|--|---------------------------|
| Code no. | WCH 1091 | WCH 1092 |
| System components | Applicator, supply unit, tool kit | |
| Weight Applicator | approx. 3.3 lbs | |
| Power requirements | 120 Volt AC / 60 Hz, with connection to ground | |
| Power input | 400 watt | |
| Current input | 3.3 A | |
| Degree of protection (to DIN IEC 34 Part 5) | IP 30 | |
| Protection class (to DIN VDE 0720) | I (safety earth terminal) | |
| Heat control | Electronic with ACE-control device (see chapter 4.4) | |
| Temperature limit | Safety thermostat 490°F, limiting thermostat | |
| Operating temperature | 122 ° to 446°F, continuously adjustable | |
| Temperature tolerance | ±2°F | |
| Factory adjustment | 258°F ± 1 K | |
| Temperature indicator | digital via LED-Display | |
| Automatic temperature reduction system (ACE) | The temperature reduced by approx. 20% if the applicator is not used for approx. 25 minutes | |
| Heat up time, approx. | 5 minutes | |
| Melting capacity, approx. (according to hot melt type) | For slugs: 5.5 lbs/h For granulate: 2 lbs/h | |
| Melt tank capacity | 5.6 oz | |
| Transport system | Compressed air | |
| Compressed air connection | max. 120 psi via hose with quick releasing fitting | |
| Operating pressure | 15 to 75 psi, continuously adjustable | |
| Overpressure safety | safety valve: 82.5 psi | |
| Air consumption | max. 3.5 oz per cycle | max 17.6 oz per cycle |
| Nozzle system | Conical nozzle 1.5 mm Ø | Spiral nozzle 1.2 mm Ø |
| Lenght of electric cord | 9.84 ft | |
| Lenght of compressed air hose | 9.84 ft | |
| Lenght of supply line | 9.84 ft | |
| Recommended hot melt glue | PAM® -hot melts as slugs (43 mm Ø) or granulate | |

2 Safety



Warning!

The applicator is used to heat hot melt glue and apply it under pressure.

If the instructions and information contained in this operating manual are not observed, or the applicator is used for a purpose other than that for which it was intended, or the applicator is modified and/or used by insufficiently trained personnel, there will be a risk of injury.

2.1 Normal use

2.1.1 Scope of application

Applicator to heat and apply metered quantities of thermoplastic materials (such as hot melt glues or waxes) in the form of bead (HB 600) or by spray application (HB 600 Spraymatic).

2.1.2 Restriction of use

The tool is designed for commercial use.

Only hot melt glues recommended by the manufacturer may be heated up and applied.

The applicator may only be handled and operated with the nozzle pointing downwards.



Do not operate the hot-melt applicator within the area of high frequency interference (e.g. mobile phones), because it will influence the temperature control.

2.2 Potential hazards



Risk of burns caused by hot metal parts and hot melt glue.



Risk of explosion in operation with oxygen or combustible gases!



Irritation of the mucous membranes by vapours emitted by hot melt glue.

2.3 Instruction on safe operation

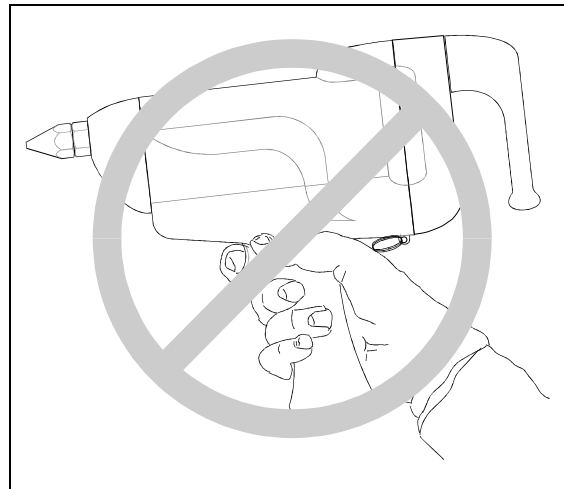
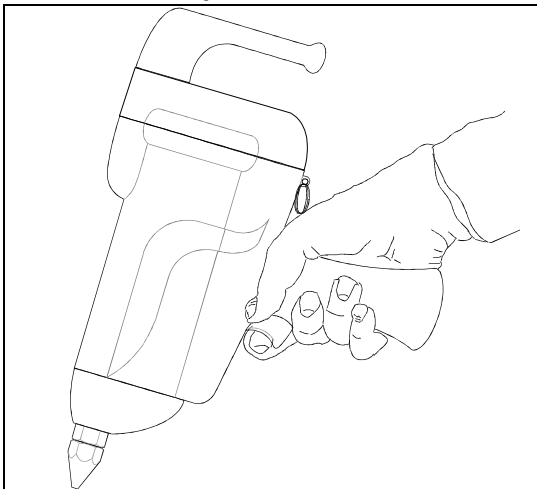

The applicator may only be used with the nozzle pointing downwards.

Do not overfill the melt tank (max. level = 1 inch below top).

If the heated applicator is tilted and/or the tank is overfilled, the hot melt glue can enter the ventilation pipe. This glue may cause malfunctions and may risk your injury.



In special situations always wear protective equipment (heat protection gloves, face shield).

Protection against injury during maintenance and repair work.



Protect the applicator against moisture and wetness.

Protection against electric shock.



Observe the instruction sheet for the hot melt glue.

Only operate in adequately ventilated rooms.

Protection against possible irritation of the mucous membranes by the hot melt glue.



Turn off the compressed air supply and electricity supply if the applicator is faulty or not operating properly and during any maintenance or repair work.

Operation settings / Operation

3 Operating settings

3.1 Setting up



Return the applicator to its supply unit or hang it up on suspension loop (16).

Never lay down in flat position!

- Place the supply unit on a flat surface where the tool cannot slip (e.g. workbench).
- To firmly install the supply unit at the place of work use the drillholes for the rubber feet.

3.2 Connecting up



The pressure of the compressed air supply must never exceed 120 psi.

The compressed air must be free of oil, condensation and acid.

- If necessary, add a pressure reducing valve with downline safety valve (reaction pressure 120 psi) and, if necessary, add suitable filters to the supply line.
- Connect the compressed air hose up to the compressed air supply with the quick-action connector (6 mm).
- Set the operating pressure (see pressure gauge, 11) initially to 15 psi using the pressure reduction valve (12).



Make sure the mains voltage is the same as the working voltage indicated on the maker's plate.

- Plug the applicator into an earthed main socket.

3.3 Switching on



As soon as the temperature controller has been switched on, the applicator heats up.

- Press the master switch "POWER" (10). A coloured dot means "On".
- ➔ The green "POWER" LED (9) lights up.
The red "HEAT" LED (8) lights up and flashes when the temperature set has been reached.
The digital display (3) indicates the actual temperature of the applicator and when the "ADJUST/MEASURE" push switch (4) is pressed it indicates the preset temperature.

3.4 Changing the temperature setting



Never set the temperature higher than the working temperature of the hot melt glue to avoid burning the glue. The temperature has been set by the manufacturer to approx. 358 °F.

- Simultaneously press the "ADJUST/MEASURE" push switch (4) and rotary knob "ADJUST" (7).
- Turn the rotary knob (7) to set the correct temperature on digital display (3).

Release the knob and push switch.

Switching off, even for a lengthy period, does not change the temperature set. Environmental conditions (as influence of strong high frequency interference / transmitter stations) and electrical fluctuations may cause differences of 0.5 - 1 °F. It is therefore recommended that the preselected temperature has to be checked occasionally and adjusted if necessary.

4 Operation

4.1 Filling



Only open the applicator when it is heated!

Protection against damage to the cover seal.



Risk of burns on hot metal parts.

- Place the applicator in the supply unit.
- Let heat up the applicator.
- Hold the applicator by the handle (17) with one hand.
- With the other hand turn the swivel handle (14) clockwise (toward "OPEN") and swing it to the right to open the cover (15).



Do not overfill the melt tank (max. level = 1 inch below top).

Hot melt glues expand with increasing temperature.

- Fill hot melt glue into the melt tank.
- Close the cover (15).

Operation / Troubleshooting

4.2 Applying and metering hot melt glue

- i** Ensure that there is always sufficient hot melt glue in the melt tank to avoid “running empty”.
 - Let the applicator heat up for approx. 5 minutes.
 - Squeeze the trigger (18).
 - You can meter the application quantity by changing the pressure (up to 75 psi) at the pressure reduction valve (12) and/or selecting an appropriate nozzle (see accessories).
- ➔ As soon as you release the trigger (18) the compressed air supply is stopped and the melt tank is vented.

4.3 Setting the spray (PAM 600 Spraymatic)

The spray can be altered by regulating the spray air.

- Establish the optimum application spray by adjusting the spray air choke (13) and by test spraying.

| Scale value | Spray air |
|---|---------------|
| 0 | without choke |
| 10 | with choke |
| For experience, optimum spray air supply is achieved at a value between 2 and 4 | |

4.4 Automatic temperature reduction system ACE (Anti Char Electronic)

To protect the hot melt glue from unnecessarily high temperature the operating temperature is automatically reduced by approx. 20% to a standby level if the applicator is not used for approx. 25 minutes.

- ➔ The red LED “ACE” (6) lights up and the digital display (3) indicates the reduced temperature.
 - Squeeze the trigger (18) or press the push switch “ADJUST/MEASURE” (4) to heat up the operating temperature again.

4.5 Stopping work / End of shift

- Press the master switch “POWER” (10) to switch off the temperature controller.
- Reduce with the pressure reduction valve (12) the operating pressure to “0” or turn the compressed air supply off.

4.6 Troubleshooting and remedying faults

- In the event of malfunctions first check the compressed air and electricity supply.

- i** In the event of a fault in the heating system a safety temperature controller prevents the applicator from heating up above 490 °F (± 11 K).

| Fault | Possible cause | Remedy | See Section |
|---|---|---|-------------------------|
| Nozzle leaks | Nozzle valve damaged | PAM 600: Change nozzle foot PAM 600 Spraymatic: Change spiral nozzle, compression spring and ball | 5.3.2 5.3.4 |
| | Air channel inside melt tank and ventilation pipe clogged | Clean | 6 |
| | Redirecting valve damaged | Change | |
| Insufficient hot melt glue or none at all is being discharged | Operating pressure too low | Increase (up to 5 bar) | |
| | No supply of compressed air | | |
| | Nozzle system blocked | PAM 600: Change conical nozzle foot if necessary PAM 600 Spraymatic: Change spiral nozzle, compression spring and ball | 5.3.1 5.3.2 5.3.4 |
| | Redirecting valve damaged | Change | 6 |
| Temperature fluctuates considerably | Fault in the heating system | Check | 6 |

Troubleshooting / Maintenance / Servicing

| Fault | Possible cause | Remedy | See Section |
|---|---|---|-------------|
| Applicator fails to heat up | Electric lead break | Change | 6 |
| | Supply line break | Change | |
| | Fault in heating system | Check | |
| Trigger (18) sticks | Redirecting valve damaged | Change | 5.4 |
| Compressed air escaping from cover | Cover pressure not enough | Increase the cover pressure | |
| Ventilation of melt tank takes longer than 2 sec. or not at all | Air channel inside melt tank and ventilation pipe clogged | Clean | 6 |
| | Redirecting valve damaged | Change | |
| Compressed air escaping from the air maintenance unit | Safety valve (1) achieved | Reduce operating pressure | |
| | Inspection glass of water separator (2) cracked | Change | |
| only PAM 600 Spraymatic | | | |
| Spray not perfect | Spray air not set correctly | Adjust | 4.3 |
| | Nozzle system blocked | Change spiral nozzle, compression spring and ball | 5.3.4 |
| Blobs after spray application | Spray after-air not set correctly | Adjust | 5.5 |

5 Maintenance / Servicing



Before carrying out maintenance or servicing which requires no power supply (electricity, compressed air), first cut off the supplies.

Wearing personal safety equipment (heat protection gloves, face shield) increases safety.

- i** **Before servicing or performing maintenance work on components which come into contact with hot melt glue they must be heated (heat up the applicator or use an external hot-air gun).**

5.1 Maintenance intervals

| | |
|---------------|--|
| Daily | Empty the water separator (2) |
| | Check the applicator for leaks, damage, missing parts and loose screws |
| Weekly | Remove any residues of hot melt glue and other dirt, particularly from the sealing surface of the cover (15) |

5.2 Cleaning

- i** **Never use strong detergents or ones containing solvents. They may damage components of the applicator. Parts which can no longer be cleaned, particularly on account of hot melt glue that has burned, must be replaced or the applicator returned to the dealer or manufacturer for cleaning or repair.**

- Remove any residual hot melt glue and other dirt mechanically, e.g. with a rag, soft brush, wood spatula or the like.

5.2.1 Cleaning the nozzle

- In the case of minor external contamination wipe the nozzle with a rag.
- In the event of clogging, insert a drill bit, needle or piece of wire through the nozzle hole.
- In cases of extreme charring replace the nozzle (see Section 5.3.1 and 5.3.4)

5.3 Nozzle systems

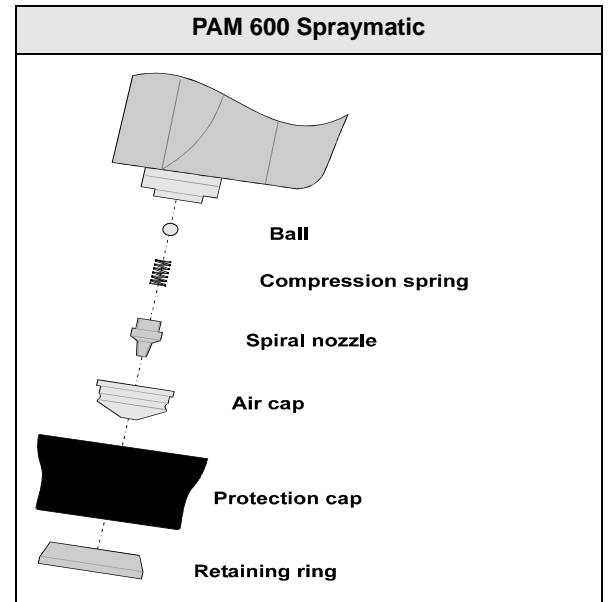
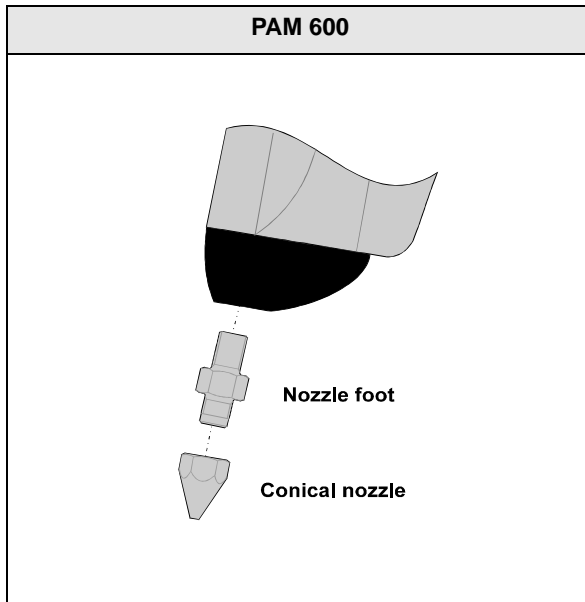

5.3.1 Changing the conical nozzle (PAM 600)

Tools required: 2 size 19 open-ended spanner

- Keep the nozzle foot from moving and unscrew the conical nozzle.
- Screw the new nozzle on hand-tight and allow the nozzle to heat up for 2 minutes.
- Keep the nozzle foot from moving and tighten the nozzle until snug. Do not overtighten!

5.3.2 Changing the nozzle foot (PAM 600)

Tools required: 2 size 19 open-ended spanner



Ensure that there is no hot melt glue in the melt tank before changing. Therefore apply the hot melt glue until the melt tank is completely empty (e.g. into a cardboard box).

- Turn off the compressed air supply and the electricity supply.
- Unscrew the conical nozzle (see Section 5.3.1).
- Unscrew the nozzle adapter.
- Reassemble as above but in reverse order.

5.3.3 Changing the nozzle-setting (PAM 600)

The position of the conical nozzle can optionally be swivelled around the center line of the melt tank.

Tools required: 1 screwdriver, 1 size 5 hexagonal recess key, 1 size 20 open-ended spanner

- Turn off the compressed air supply and the electricity supply.
- Remove the cylinder screw in the diffusor cap (20).
- Take off the diffusor cap (20) and the diffusor disk underneath.
- Loosen the hollow set screw of heating labyrinth by half a rotation.
- Turn the heating labyrinth by means the open-ended spanner and then change thus the nozzle arrangement.
- Reassemble as above but in reverse order.

5.3.4 Changing the spiral nozzle, compression spring and ball (PAM 600 Spraymatic)

Tools required: 1 pin spanner, 1 size 11 open-ended spanner



Ensure that there is no hot melt glue in the melt tank before changing. Therefore apply the hot melt glue until the melt tank is completely empty (e.g. into a cardboard box).

- Turn off the compressed air supply and the electricity supply.
- Undo retaining ring without using force.
- Remove the protection cap (19) and the air cap.
- Unscrew spiral nozzle.
- Compression spring and ball are located behind the nozzle.
- Reassemble as above but in reverse order.

Maintenance / Servicing / Repairs

5.4 Increasing the cover pressure

If air leaks through cover, the lid pressure has to be increased.

- Tools required: 1 screwdriver
- Turn adjusting screw through the borehole in the middle of the cover (15) clockwise until snug, and then go one more turn.
- Check if cover can be closed without using force

i If the leak cannot be rectified, change the O-ring seal.

5.5 (Setting the spray after-air (PAM 600 Spraymatic))



Changes to the electronic controller may only be performed by authorized electrical personnel.

The spray after-air cleans the nozzle after application of hot melt glue. After-air time has been set by the manufacturers to approx. 1 second and should only be altered in exceptional cases.

The potentiometer for controlling spray after-air is located behind the protection cap (5).

6 Repairs



Repair work may only be performed by authorized personnel using original spare parts.



Repair work on the electrical equipment may only be performed by authorized electrical personnel using original spare parts. Repairs must be performed in accordance with DIN standard 57701 and VDE 0701.

For your safety, send a faulty applicator to the dealer or manufacturer for repair.

Accessories

Stand

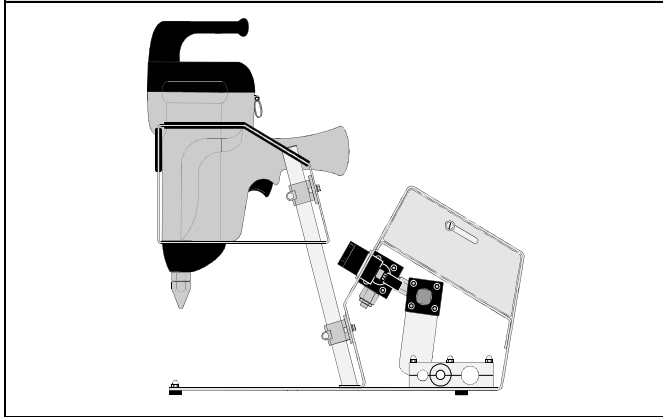

Quick exchange nozzles

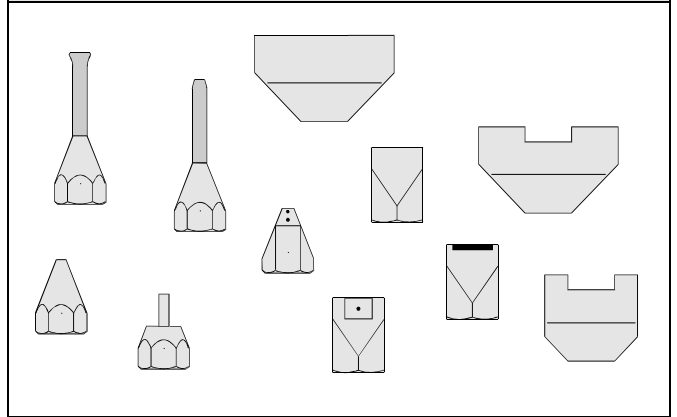

Guarantee

This equipment was designed and manufactured according the latest technology. We guarantee the original buyer proper function, material and workmanship for a period of 6 months after delivery. Normal wear and tear excluded.
The guarantee is null and void when improper handling, use of force, repair by third parties and use of non-origine-parts can be established, or if the tool is used improperly, or used to apply substances other than hot melts.
The guarantee extends to either repair or exchange according to our choice.
A warranty extending further than the items covered by delivery is excluded as we have no influence over the operation of the equipment and hot melts.
Please observe our General Terms of Sale.

PAM®

FASTENING TECHNOLOGY, INC.
Division of BUEHNEN Group, Germany

*P.O. Box 669063, 2120 Gateway Blvd.,
Charlotte N.C. 28266
Telephone: (704) 394 3141,
FAX: (704) 394 9339*

